

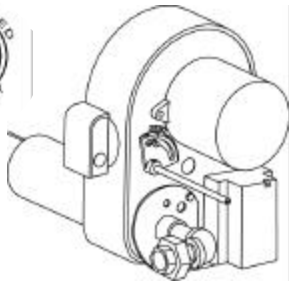

Midco
INTERNATIONAL



Economite RE4400DS & RE4400DSA Gas Burner

In the United States, Installation must conform with local codes or, in the absence of local codes, with Installation of the **National Fuel Gas Code, ANSI Z223.1-latest edition**, from the American National Standard Institute. Further reference should be made to the recommendation of your fuel supplier.

In Canada, Installation must conform with local codes or, in the absence of local codes, with **Installation Codes for Gas Burning Appliances and Equipment, CGA Standard CAN/CGA 1B-149**. Further reference should be made to the recommendation of your fuel supplier.

⚠ WARNING: Additions, changes, conversions, and service must be performed by an authorized MIDCO representative, service agency, or the fuel supplier. Use only MIDCO specified and approved parts.

INSTALLER: Inform and demonstrate to the user the correct operation and maintenance of the gas utilization equipment. Inform the user of the hazards of storing flammable liquids and vapors in the vicinity of this gas utilization equipment and remove such hazards. Affix this manual and associated literature adjacent to the burner. **CODE COMPLIANCE IS THE SOLE RESPONSIBILITY OF THE INSTALLER.**

USER: Retain this manual for future reference. If other than routine service or maintenance as described in this manual and associated literature is required, contact a qualified service agency. **DO NOT ATTEMPT REPAIRS.** An inadvertent service error could result in a dangerous condition.

FOR SERVICE CONTACT:

Name _____

Address _____

Phone _____

Date of Installation _____

⚠ WARNING: If the information in these instructions is not followed exactly, a fire or explosion may result, causing property damage, personal injury or death.

Do not store or use gasoline or other flammable vapors and liquids in the vicinity of this or any other appliance.

WHAT TO DO IF YOU SMELL GAS:

- ⚠ Do not try to light any appliance.
 - ⚠ Do not touch any electrical switch; do not use any phone in your building.
 - ⚠ Immediately phone your gas supplier from another building. Follow the gas supplier's instructions. If you cannot reach your gas supplier call the fire department.
- Installation and service must be performed by a qualified installer, service agency or the gas supplier.

⚠ **AVERTISSEMENT.** Assurez-vous de bien suivre les instructions données dans cette notice pour réduire au minimum le risque d'incendie ou d'explosion pouvant entraîner des dommages matériels, des blessures ou la mort.

Ne pas entreposer ni utiliser d'essence ni d'autres vapeurs ou liquides inflammables à proximité de cet appareil ou de tout autre appareil.

QUE FAIRE SI VOUS SENTEZ UNE ODEUR DE GAZ:

- Ne pas tenter d'allumer d'appareil.
- Ne touchez à aucun interrupteur. Ne pas vous servir des téléphones se trouvant dans le bâtiment où vous êtes.
- Appelez immédiatement votre fournisseur de gaz depuis un voisin. Suivez les instructions du fournisseur.
- Si vous ne pouvez rejoindre le fournisseur de gaz, appelez le service des incendies.

L'installation et l'entretien doivent être assurés par un installateur ou un service d'entretien qualifié ou par le fournisseur de gaz.

Burner Model _____

Bill of Material # _____

Serial Number _____

Wiring Diagram _____

SAFETY INFORMATION TERMS: The following terms are used to identify hazards, safety precaution of special notations and have standard meanings throughout this manual. They are printed in all capital letters using a bold type face as shown below, and preceded by the exclamation mark symbol. When you see the safety alert symbol and one of the safety information terms as shown below, be aware of the hazard potential.



DANGER: Identifies the most serious hazards which **will** result in severe personal injury or death.

WARNING: Signifies a hazard that **could** result in personal injury or death.

CAUTION: Identifies unsafe practices which would result in minor personal injury or product and property damage.



Midco® International Inc.

4140 West Victoria St. - Chicago, Illinois 60646
tel 773.604.8700 fax 773.604.4070
web www.midco-intl.com e-mail sales@midco-intl.com

Quality Designed for Proven Performance



602
8471 25
Printed in U.S.A.

Specifications ¹

The **ECONOMITE Model RE 4400DS and RE4400DSA** burners with direct spark ignition are adaptable to most gas utilization equipment, including furnaces and boilers. Power burner design makes them perfectly suited for oil burner replacement, including rooftop and industrial applications.

AIR DELIVERY (Approximate Air Delivery at Zero Draft)	
RE 4400DS and RE4400DSA 125 SCFM ₂
FIRING RATE (NATURAL OR PROPANE) ₃	
RE4400DS & RE4400DSA	
MAXIMUM MBH ₄	400
MINIMUM MBH ₄	132
GAS SUPPLY PRESSURE REQUIRED	
NATURAL	7.0" to 14.0" W.C.
PROPANE	5.0" TO 14.0" W.C.
TUBE DIAMETER.....	4"
TUBE LENGTH.....	9"
RECOMMENDED COMBUSTION CHAMBER SIZE (AT MAX. BTU/HR)	
RE4400DS & RE4400DSA	
WIDTH	10"
LENGTH	16.5"
ELECTRICAL SUPPLY.....	120 VAC.....60 Hertz ₅
ELECTRONIC CONTROL VOLTAGE	24 VAC
FLAME SAFETY....Direct Spark Ignition of Main Flame, Electronic Safety	

TABLE 1: Burner Specifications

- Standard burners are shipped as NATURAL gas models. Contact your Midco® dealer for PROPANE gas burners.
- SCFM = Standard Cubic Feet / Minute.
- All Ratings Based on 1000 BTU/Cu. Ft. NATURAL and 2500 BTU/cu.ft PROPANE. Derate burner for altitude over 2,000 feet by 4% for each 1,000 feet above sea level.
- 1 MBH = 1,000 BTU/hr.
- For 50 Hertz applications the RE4400DS and RE4400DSA will be derated by 20%. Contact the factory for details. NOTE: Burners rated for 50Hertz are not UL Listed.

Part 1 Installation

I Ventilation

⚠ CAUTION: The ECONOMITE Model RE4400DS and RE4400DSA Burners are not intended for outdoor installation and must be protected from excessive moisture. Provide adequate clearance for service and proper operation.

If the former automatic oil burner gave trouble-free operation, it is probable that the heating plant area has sufficient infiltration of air for combustion and dilution of flue gases. **Nevertheless, the area must be checked.**

⚡ Open basement or utility areas of normal construction, without storm windows or tight doors, will generally allow sufficient air infiltration. However, if the heating plant is located in a tight or separate room, ventilation to an open area as described above will be required. Install two permanently open grills, each sized on the basis of one square inch free area per 1,000 BTU (but not less than 100 square inches) of the total input rating of all gas utilization equipment in the combined space. One grille should be located within 12 inches of the ceiling, the other within 12 inches of the floor.

⚡⚡ If the heating plant is located in an area of unusually tight construction, or if an exhaust fan, kitchen ventilation system, clothes dryer and/or fireplace is installed in the building, provisions must be made for an outside air supply near the heating appliance area. Install permanently open grills sized at not less than one square inch free area per 4,000 BTU of burner input. When ventilating through horizontal ducts, grills should be sized at not less than one square inch free area per 2,000 BTU of burner input. In any case, the minimum dimension of rectangular air ducts shall not be less than 3 inches.

⚡ In Canada, for detailed ventilation requirements, refer to standard CAN 1-B149.1 or .2 and/or local codes.

II Preparation of the Gas Utilization Equipment

⚡ Clean the gas utilization equipment combustion chamber, heat exchanger interior, and flue connections. Remove all adhering tars, scale, dirt and soot. Inspect for actual or potential leaks.

⚡ Cement all joints, including those in the heating appliance base and around the door frames, to prevent leakage into, or out of the combustion chamber.

⚡ The access or firing door should open easily to relieve pressure. If positive latches exist, they should be modified to permit easy opening; a spring loaded door holder is recommended.

⚡ On all boilers, make certain the pressure relief safety valve is in good operating condition.

Part 1
Installation Continued
III Combustion
Chamber

A combustion chamber liner is normally required to protect non-heat transfer surfaces and to provide a radiant bed for rapid heat transfer to the primary surfaces of the heat exchanger. In most cases the existing chamber liner can be used, if in good condition.

⚡ In the case of wet base boilers, where the entire firing chamber is comprised of heat exchange surfaces and no chamber liner was provided for oil firing, a liner is usually not required for the ECONOMITE. However, a liner or target wall may be necessary if the firing chamber is unusually short, in order to avoid excess flame contact on the heat exchanger walls or flueways.

⚡ If a built up chamber liner is required, use 2,300°F minimum insulating material.

⚡ The burner tube, or the stainless steel sleeve that is included with the burner, must be sealed air tight into the combustion chamber opening with refractory material. The sleeve is preferred as it is designed to properly locate the end of the tube relative to the inside wall of the combustion chamber, and to permit burner removal without breaking the seal.

⚠ CAUTION: In no case should the burner tube be allowed to extend into the chamber proper; it must be set at least 1" short of the inside surface because high combustion chamber temperatures will cause premature pilot, electrode, burner tube and sleeve deterioration.

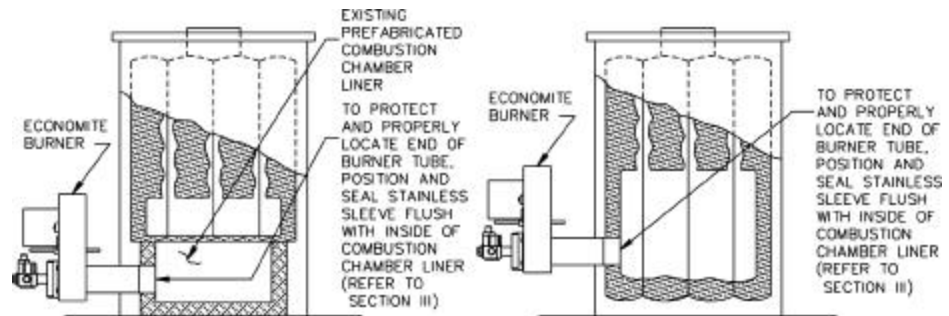

Figure 1: Dry Base Boiler with Combustion Chamber Liner (Warm Air Furnace Construction is Similar)

Figure 2: Wet Base Boiler with Unlined Combustion Chamber

⚠ WARNING: BURNER MUST BE MOUNTED IN ORIENTATION SHOWN IN FIGURES 1 AND 2. ANY OTHER MOUNTINGS MAY CAUSE A DANGEROUS CONDITION, AND WILL VOID BURNER WARRANTY AND AGENCY APPROVALS. NON-STANDARD ARRANGEMENTS MAY BE AVAILABLE FOR SOME MODELS. CONSULT FACTORY FOR DETAILS IF REQUIRED.

⚡ Before permanently setting the burner in place, check that the main burner ports are free of foreign materials, and also that the spark electrode assembly has not been damaged or displaced. See Figures 7A and 7B.

IV Chimney, Vent
Connector and
Draft Control

⚠ WARNING: The chimney shall be inspected for unsafe conditions such as deteriorated masonry and excessive soot or other blockage or potential blockage. Installation must conform with local codes or in the absence of local codes with NFPA, ANSI Z223.1 latest edition.

⚠ WARNING: The vent connector shall not be connected to a chimney already venting solid fuel burning equipment, an incinerator or an open fireplace.

⚡ The Vent Connector shall be made of non-combustible, corrosion resistant material capable of withstanding the vent gas temperature produced by the gas utilization equipment and of sufficient thickness to withstand physical damage.

⚡ The Vent Connector shall be as short as possible. The entire length shall be readily accessible for inspection, cleaning, and replacement.

⚡ The length of horizontal uninsulated Vent Connector between the chimney and a single gas utilization equipment shall not exceed 75% of the height of the chimney above the connector, or 100% if the Vent Connector is insulated.

⚡ The Vent Connector shall be installed so as to avoid turns or other construction features which create excessive resistance to flow of vent gas. It shall be installed without any dips or sags and shall slope upward at least 1/4" per foot.

⚡ A manually operated damper shall not be placed in the Vent Connector or chimney of any gas utilization equipment.

⚡ The Vent Connector shall be firmly attached to draft hood outlets and flue collars. Joints between sections of connector piping shall be fastened by sheet-metal screws or other approved means. The Vent Connector shall be supported for the design and weight of the material employed to maintain clearance and prevent physical damage and separation of joints.

Part 1
Installation Continued
IV Chimney, Vent
Connector and
Draft Control
Continued

⌘ A draft hood or a barometric draft regulator shall be installed in the same room or enclosure as the equipment in such a manner as to prevent any difference in the pressure between the hood or regulator and the combustion air supply (see Figures 3 and 4). In no case shall the relief opening of the draft hood or barometric draft regulator be located at a point lower than the top of the highest flue passage in the equipment.

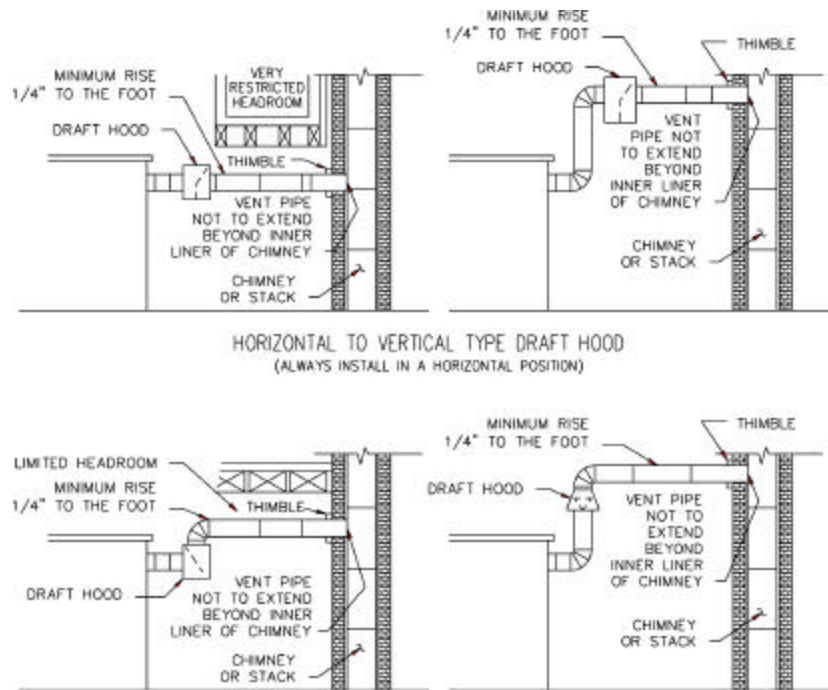
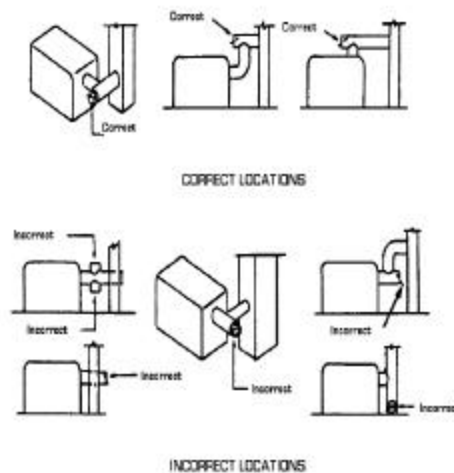

Figure 3: Recommended Locations for Draft Hoods



*Note: Figure 3 and 4 :
 Copyright by American Gas
 Association.
 Used by permission of the
 copyright holder.*

**Figure 4: Location for Barometric
 Draft Regulators**

- ⌘ Gas utilization equipment requiring controlled draft may be equipped with a listed double acting barometric draft regulator, if approved by local codes (see Figure 4).
- ⌘ If a device which will automatically shut off the gas to the burner in the event of sustained backdraft is required. It shall be of the listed manual reset type and installed and adjusted by a qualified service technician in accordance with the manufacturer's instructions.
- ⌘ Refer to gas utilization equipment manufacturer for recommended vent connection requirements.

V Electrical

⚠ CAUTION: Refer to wiring diagram in Figure 5 or located on the inside of the burner housing cover.

Installation wiring and grounding to the burner must conform to local codes, or, in their absence in the **United States to National Electric Code, ANSI/NFPA No. 70** latest edition; in **Canada, to Canadian Electrical Code Part 1, CSA Standard C22.1**

- ⌘ Use copper wire not less than 14 gage for line voltage wiring. Hook up to a dedicated line with an on-off disconnect switch and a minimum 10 Amp breaker.
- ⌘ The frame of the burner should be well grounded. Normally the piping and/or electric

Part 1
Installation Continued
V
Electrical
Continued

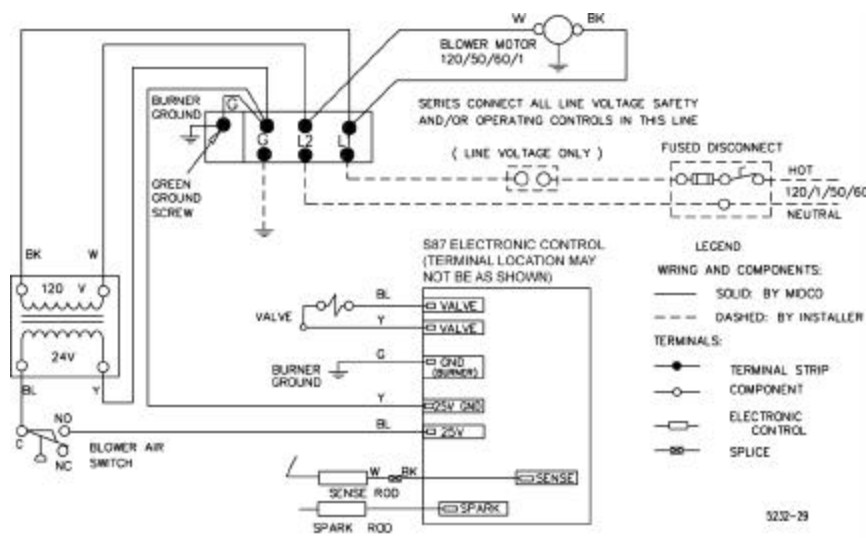

Figure 5: Wiring Diagram

conduit will provide sufficient grounding. However, a ground lug is located in control box for positive grounding where insulated pipe couplings are used or where any doubt exists regarding grounding sufficiency.

- ⚠ Confirm that the polarity is correct—hot wire to strip terminal L1, neutral L2—and that the neutral line is not subject to induced low voltage (check L2 to earth ground) from other equipment, as that can cause the Electronic Control to malfunction.
- ⚠ Each installation must include suitable limit control(s). Existing oil burner combination operating and limit controls are normally NOT SUITABLE for gas burner use.
- ⚠ Connect motors used on forced air furnace fans or boiler pumps to a combination limit control and switch.
- ⚠ Set the thermostat heat anticipator for the total current draw handled by the thermostat. The current draw of the ECONOMITE 24V operating circuit is 0.9 amps.

⚠ CAUTION: Label all wires prior to disconnection when servicing controls. Wiring errors can cause improper and dangerous operation. Verify proper operation after servicing.

VI Piping

⚠ CAUTION: The available gas pressure should be within the limits shown in Table 1 - SPECIFICATIONS section. Excessive pressure may damage electric valves, regulators and manual valves. If the supply pressure exceeds the 14.0"W.C. maximum, a suitable high pressure regulator must be installed between the Main Manual Shut-Off Valve and burner combination valve as shown in Figure 6.

- ⚠ The burner gas supply piping should branch off from the main line as close to the gas meter as possible. Do not connect to the bottom of a horizontal section. Use new black pipe and malleable fittings free of cutting and threading burrs or defects.
- ⚠ Provide a sediment trap, union and 1/8" pressure tap in piping close to burner as shown in Figure 6.
- ⚠ Use pipe joint compound approved for use with Liquid Petroleum Gases.
- ⚠ Piping must also comply with your local codes.
- ⚠ To obtain the maximum firing rate of the burner, the gas supply piping must be sized to provide a minimum pressure of 7.0"W.C. (Natural) and 5.0"W.C. (Propane) to the inlet of the combination redundant valve when the burner and all other gas utilization equipment are on. The main regulator, if equipped, should be mounted upright and in a horizontal run of pipe.

⚠ CAUTION: Because it is difficult to accurately control pressure during supply pipe leak testing, it is recommended that all low pressure (14.0"W.C. max.) components be disconnected during testing. Exposing low pressure regulators and valves, including manual valves, to pressures over 1/2 PSIG (14.0"W.C.) will cause damage and void all warranties.

⚠ DANGER: Explosion hazard.
Do not use oxygen for pressure testing.
An explosion could occur during initial start up.

- ⚠ If the burner piping must be rearranged because of space limitation, be sure to carry out the general arrangement shown in Figure 6. Install the combination valve in any position except up-side down.

Part 1
Installation Continued
VI
Piping
Continued

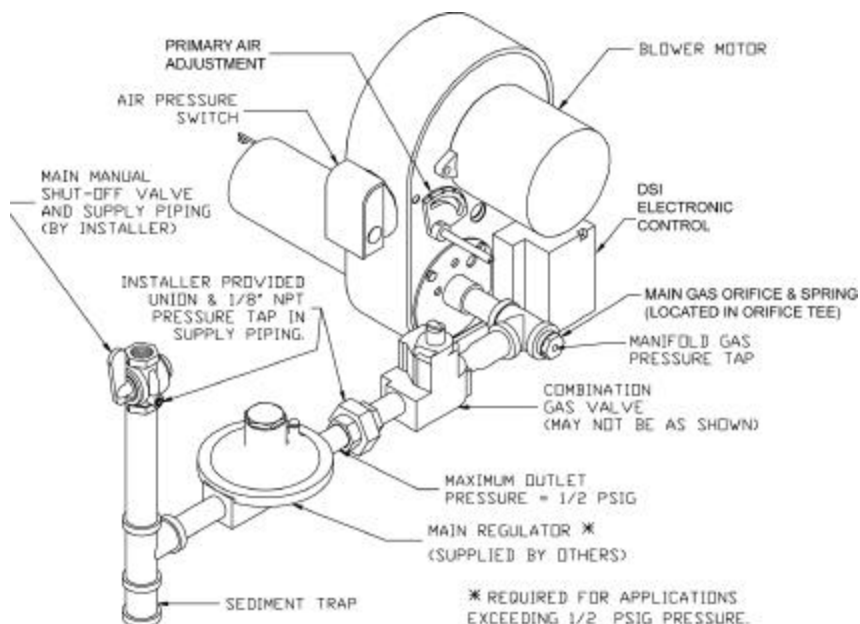

Figure 6: Piping Diagram

- ⌘ When the burner is installed in the vestibule of jacketed equipment, it is recommended that the Automatic Safety Shut-Off Valves be left adjacent to the burner within the vestibule and the Main Manual Shut-Off Valve be installed outside.
- ⌘ Run full size pipe or tubing from regulator vent openings to outside of building. Provide no traps in the vent lines and terminate away from all doors and windows; also make provisions for keeping rain and foreign objects from entering the vent piping.
- ⌘ When high supply gas pressure is encountered, as in the case in many industrial plants, the gas line size can be reduced to allow for a greater pressure drop; however, the size must be sufficient to deliver burner rating pressure.

Pipe Size	Type of Gas	Approximate Capacity -MBH				
		Pipe Length				
		10	20	40	75	100
3/4	Natural	200	150			
3/4	Propane	590	400	275	190	160
1	Natural	400	275	200	150	
1	Propane			500	360	300
1 1/4	Natural			450	325	275
1 1/4	Propane					630
1 1/2	Natural			650	475	400

Natural Gas capacities shown are for a total pressure drop of 0.3"W.C. For 0.5"W.C. pressure drop, multiply capacity shown by 1.3. Propane capacities shown are for a total pressure drop of 0.5"W.C. For higher permissible pressure drops, consult your gas supplier.

Table 2: Schedule 40 NPT Pipe-Capacity Chart

CAUTION: High gas pressure supply lines require the proper pressure reducing regulators. Install a high pressure regulator of the Tight Shut-Off type, sized for main gas input, upstream of the low pressure regulators.

- ⌘ The high pressure regulators must be adjustable to 14" W.C. outlet pressure.
- ⌘ When the gas supply line is about to be put into service it must be tested to insure that it is gas tight. Use air or inert gas under pressure and test with soap and water to locate leaks.
- ⌘ Before gas is turned onto the system, a check must be made to see that there are no open fittings and to make sure the burner main valve is closed.
- ⌘ After checking for leaks, purge the gas line up to the burner inlet. Purging the air from the gas supply line at this step will expedite the first light-off.

NOTE: If there is more than 1.0" W.C. differential in the inlet pressure to the burner compared to when all other gas utilization equipment are off, refer to Section VII.

Part 1
Installation Continued
VII Main Gas
Input Selection

VIII Initial Start-up /Adjustment

Burners are approved for use with NATURAL gas or PROPANE gas and should be used only with the gas specified on the rating plate. If the supplied burner is designed to run on natural gas and needs to be changed to run on propane, a conversion kit is available from Midco®.

⚠ The gas input should be set at the heating rate determined by the building heat loss and/or heating plant survey, but not exceeding the rated maximum input of the gas utilization equipment or Economite burner.

⚠ WARNING: Ignition is automatic. Make spark observations into combustion chamber only with Main Manual Shut-Off Valves closed. Confirm that gas utilization equipment does not contain any accumulated gases. Purge as described in step 3 below.

⚠ CAUTION: Cover plates, guards, and enclosures must be maintained in place at all times except during maintenance and service.

1. Check the burner piping and valves for gas leaks by applying a weak liquid soap solution to unions and joints with the gas supply on. Leakage will be indicated by the appearance of soap bubbles. Locate and correct all gas leaks before proceeding.

⚠ WARNING: DO NOT USE OPEN FLAME.

2. Purging the air from the gas supply line at this step will expedite first light-off. **IMPORTANT: Purge outside the building. Do not purge into the gas utilization equipment.**

3. To purge the gas utilization equipment and chimney of any accumulated gases, turn main Manual Gas Cock **OFF**, turn burner power on, and set operating control to **ON** or thermostat to call for heat. Let the blower run long enough to accomplish four combustion chamber volume air changes, but not less than five minutes.

Natural Gas / Propane Gas Orifice Size and Pressure Settings

Input MBH	Natural Gas			Propane Gas		
	Orifice Size (Inches)	Letter Stamp	Manifold Pressure ("W.C)	Orifice Size (Inches)	Letter Stamp	Manifold Pressure ("W.C)
RE4400DSA						
400	No Orifice	-	4.7	0.358	J	3.5
350	No Orifice	-	3.6	0.290	B	4.7
300	No Orifice	-	2.7	0.261	C	4.2
250*	0.358	J	3.3	0.219	E	4.8
200	0.290	B	3.5	0.219	E	2.8
132	No Orifice	-	0.6	0.358	J	0.45
RE4400DS						
400	No Orifice	-	4.3	0.358	J	2.8
350	No Orifice	-	3.3	0.290	B	3.6
300	No Orifice	-	2.4	0.261	C	3.1
250*	0.358	J	2.9	0.219	E	3.2
200	0.290	B	2.8	0.219	E	2.1
132	No Orifice	-	0.6	0.358	J	0.3

Table 3: Capacity and Preliminary Gas Settings
 DATA FOR TABLES IS APPROXIMATE AND BASED ON "0" OVERFIRE PRESSURE AT SEA LEVEL

1. Adjust the main regulator to vary the manifold gas pressure and burner input within the range shown. Do not exceed pressure as listed in Table 3, under any circumstances. Use combustion readings (CO and O₂) and a flow meter to determine exact inputs.

* Spud Size and approximate manifold gas pressure setting: as shipped. Air shutter set full open.
 NOTE: For LP Conversion kit contact the factory

⚠ CAUTION: Make sure that the capacity range of the burner, manifold pressure, and the preliminary combustion air shutter setting are suitable for capacity rating of the gas utilization equipment. Refer to Section VIII and Table 3.

Part 1
Installation Continued
VIII Initial Start-up /Adjustment
Continued

4. **RESET** the Electronic Control by setting the operating control to **OFF** or the thermostat below room temperature for at least 30 seconds. See Section XII.
5. Confirm that Main Manual Shut-Off Valves are open. Turn main Manual Gas Cock **ON**.
6. Turn operating control to **ON** or set thermostat above room temperature. Main flame should come on after the 30 second pre purge period. Whenever the burner fails to light during the 6-second ignition trial, or if the flame is lost during the burner run and is not re-established within 36 seconds, the Electronic Control will shut off the Combination Valve and **LOCK OUT**. To **RESET** the Electronic Control for restart, de-energize the Electronic Control by setting the operating control to **OFF** or thermostat below room temperature for at least 30 seconds. If burner still fails to light, turn it off and repeat from step 5 above. Then, if necessary, refer to the **TROUBLE CHART** to isolate the problem.

⚠ WARNING: Repeated unsuccessful attempts to light will result in accumulated gases in gas utilization equipment and chimney. To prevent these gases from reaching an explosive level, periodically purge the gas utilization equipment and chimney as described in step 3 above.

7. To make a preliminary setting of the burner input, determine the manifold gas pressure required from Table 3 and adjust the Main Gas Pressure Regulator accordingly. See Section XI.
8. To determine the firing rate for **NATURAL** gas, accurately time test dial for the number of seconds for one revolution and use the following formula. All other gas utilization equipment must be off.

$$\frac{3600 \times \text{test dial size} \times \text{BTU value}}{\text{No. of seconds for one rev. test dial}} = \text{BTU/Hr.}$$

Then divide by 1,000 for MBH value.

Example:
$$\frac{3600 \times 1 \times 1000}{10} = 360,000 \text{ BTU/HR} = 360 \text{ MBH}$$

9. Check the operation of the burner; start and stop it several times with the thermostat or operating control.
10. With the burner running, check the operation of all limit and associated controls.
11. Perform the following final adjustments for combustion and flue gas temperature. Take the

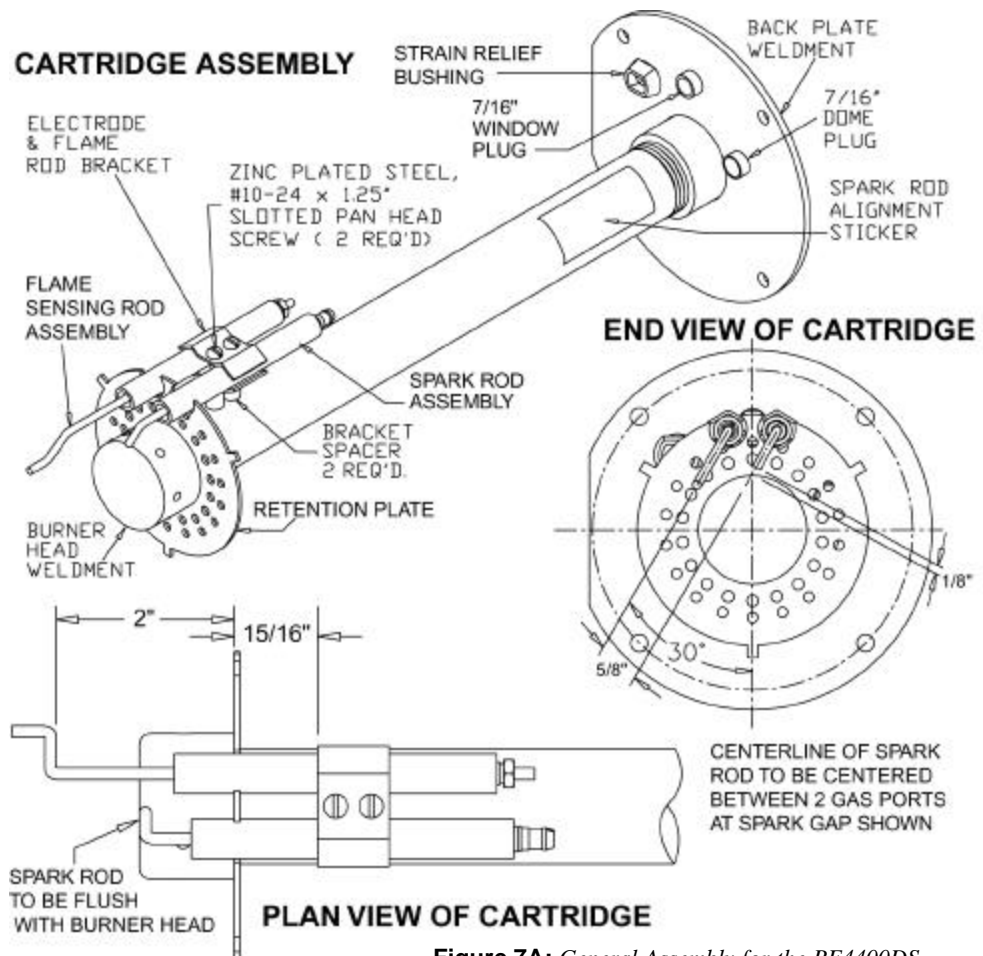

Figure 7A: General Assembly for the RE4400DS

Part 1
Installation Continued
VIII Initial Start-up /Adjustment
Continued

- flue gas samples and temperature immediately ahead of the draft control.
- A. The flue gas temperature should be above 325°F but not exceeding 550°F. Excessive flue gas temperatures will result in low efficiencies. Low flue gas temperature may cause excessive condensation. Reset gas input, if necessary, to adjust stack temperature.
 - B. Make the final setting of the combustion air shutter by checking the flue gases with an **ORSAT** or similar combustion testing instrument. The carbon monoxide content should conform to local codes, or in their absence, to the level specified in the United States or Canadian Standard referenced on the front cover of this manual; and the carbon dioxide content should be approximately 9.5% for NATURAL or 12% for propane, or within the limits prescribed by local codes.
12. Check the draft control to make sure there is no spillage of flue products into the room.
 13. **FILL OUT THE INSTALLATION ADJUSTMENT DATA TAG** and affix to the burner or gas utilization equipment.

NOTE: For subsequent normal starting and shut off procedure, refer to **CONSUMER INSTRUCTIONS**, located in part 3 of this manual, or to the instruction plate mounted on the burner.

Part 2
Service

- ⚠ DANGER:** Do not tamper with the unit or controls. If trouble occurs contact the installing contractor, service agency, or fuel supplier. See front cover.
- ⚠ DANGER:** Be sure that the main Shut-Off Valve is closed and the burner power supply is turned off before removing any parts for service.
- ⚠ CAUTION:** Cover plates, guards, and enclosures must be maintained in place at all times except during maintenance and service.

IX Electrodes

- ⚡ The flame sensing rod must be positioned as shown in Figures 7A and 7B so that the Electronic Control will detect a proper flame.
- ⚡ Both the spark and flame rods are current carrying conductors and, along with their connecting wires, must be kept free of contact with conductive metal parts of the burner. Rod insulators and wire insulators should be clean, dry and free of cracks.

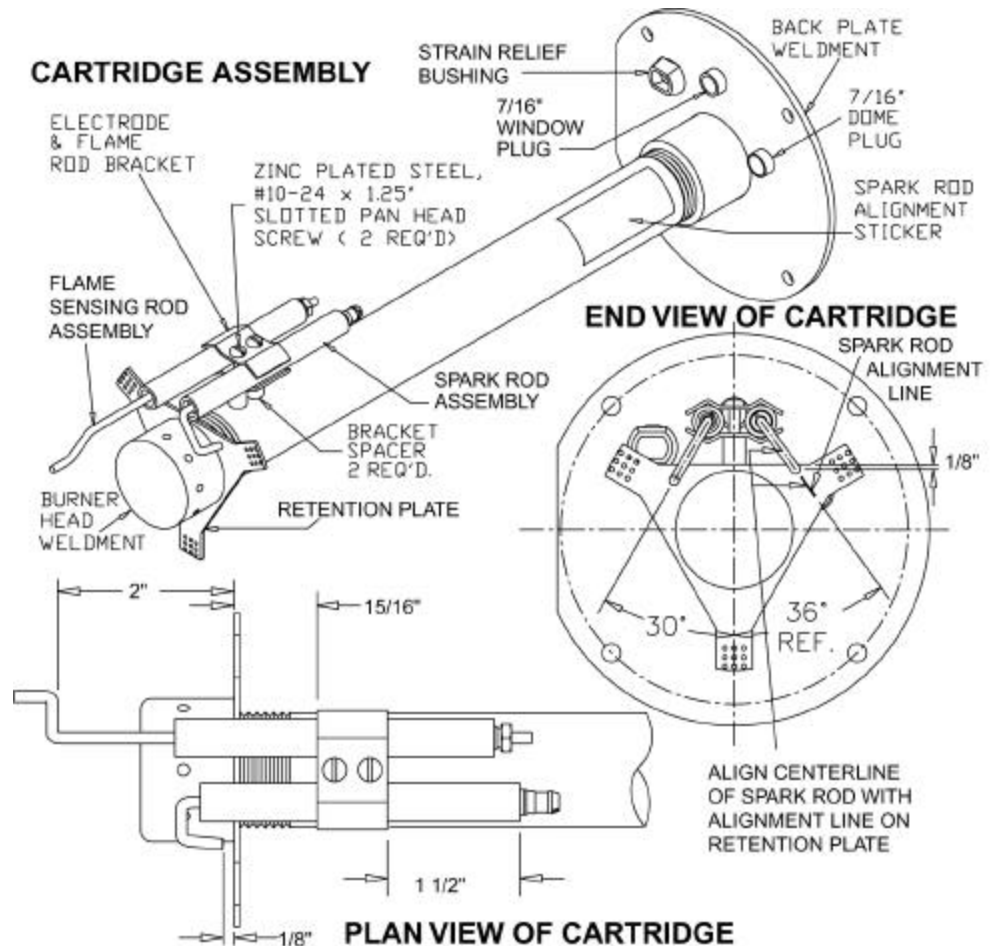

Figure 7B: General Assembly for the RE4400DSA

Part 2
Service Continued
IX Electrodes
Continued

✍ Both the spark and flame rods are made from heat resistant alloys and can be expected to have a long service life. They should be routinely inspected, however, for corrosion or loss of metal.

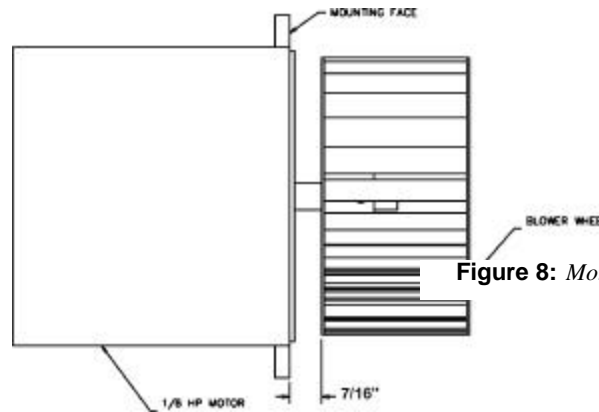

Figure 8: Motor / Blower Assembly

X Motor Blower
Interlock

⚠ CAUTION: BEFORE SERVICING, mark with a scribe line or measure opening of air controlling shutter, so that it can be reset to its original position following servicing.

✍ Cleaning of the blower wheel is usually the only service required. Need for cleaning is indicated if the character of the flame indicates a deficiency of air. Motor cooling air vents (if present) should also be cleaned at this time.

✍ The motor and wheel are removed as an assembly. Disconnect the motor conduit from the motor and remove the mounting bolts.

✍ The burner is equipped with a diaphragm type air pressure switch so as to prevent the burner from firing if the blower wheel is not running at its operating speed. When the motor is off there is no air pressure present to activate the pressure switch and in turn there is no power flow to the Electronic Control.

✍ To make a specific test of the interlock circuit:

1. Turn burner power **OFF**.
2. Turn Manual Gas Cock **OFF**.
3. Disconnect the motor wire from the terminal strip to keep the motor off.
4. Turn burner power **ON** and set the operating control to **ON** or thermostat to call for heat. Verify there is 120VAC line voltage by using a multimeter. Check for 24V between the Electronic Control **25V** and **25V GND** terminals.
 - A. No voltage: Interlock circuit OK.
 - B. Voltage present: check that the switch is wired properly or check switch operation. Replace if switch tests bad.

XI Valve Train

✍ Should replacement or service be required, valve manufacturer's instructions must be followed as outlined in their information sheet.

✍ Outlet pressure settings must be checked while the gas is flowing.

✍ To adjust outlet pressure, remove the seal cap for access to the adjusting screw. Turning the screw clockwise will increase outlet pressure, counter clockwise will decrease outlet pressure.

XII Sequence of
Operation

✍ The RE4400DS and RE4400DSA operate when power is applied to L1 and L2 through a safety and or operating control. With power applied to L1 and L2 the blower motor starts. Once the diaphragm air flow switch proves blower operation power is applied to the S87 Electronic Control. The S87 Electronic Control provides the switching of the gas valve and ignition sequence. If the flame signal is above 2DC micro amps the RE4400DS and RE4400DSA will remain in operation until a safety or operating control opens the circuit to L1 and L2. For a more thorough explanation of the Honeywell electronic control refer to the literature provided with the power burner. For startup information see section VIII.

XIII Electronic
Control

✍ The S87 is a low voltage, solid state, direct spark ignition control module for gas-fired furnaces, boilers and heating appliances. UL Listed models are only available with a pre-purge timer. The S87 controls the gas valve, monitors the main burner flame and generates a high voltage for spark ignition.

✍ The S87K uses separate electrodes for spark ignition and flame sensing. Use with any gas control designed for DSI application that is rated at 2.0 A or less. Includes a 30 second

*Part 2
Service Continued
XIII Electronic
Control Continued
XIV Special
Equipment
(OEM Versions)*

*Part 3
Maintenance and
Trouble Chart

Maintenance*

Trouble Chart

*I Motor Will
Not Run or Motor
Runs in Repeated
Cycles*

*II Motor Runs
Continuously, But
No Flame*

(minimum) delay for use with system pre-purge.

☒ For operation characteristics, maintenance, and service procedures, refer to manufacturer's literature provided with burner, or contact your Honeywell dealer.

Special equipment, either factory or contractor installed, may cause variation in the procedures and descriptions given in this manual.

Consult the OEM's manual to identify the differences in the information.

CONSUMER INSTRUCTIONS

☒ Keep the area around the burner clear and free of combustible material, gasoline or other flammable liquids or vapors. Do not obstruct burner air openings or ventilation grills for combustion air.

☒ After 3 years of normal service, the motor bearings need to be reoiled annually with 10 drops of 5W30 oil.

⚠ WARNING: If any flame is observed when the burner is on standby, or if the ignition spark or valve operator is heard to come on before the motor reaches operating speed, immediately turn off the manual gas control and burner power. A dangerous condition has developed and must be corrected. CONTACT A QUALIFIED SERVICE TECHNICIAN FOR CLEANING, READJUSTMENT OR REPAIR.

☒ Check that the ignition spark does not come on before the motor reaches operating speed. If it does, the air switch is defective and must be replaced. (See Section X, Motor / Blower Interlock).

LIGHTING INSTRUCTIONS

1. SET OPERATING CONTROL TO **OFF** OR THERMOSTAT BELOW ROOM TEMPERATURE.
2. TURN MANUAL GAS COCK **ON**.
3. TURN BURNER POWER **ON**.
4. SET OPERATING CONTROL TO **ON** OR THERMOSTAT TO CALL FOR HEAT.
5. WAIT 36 SECONDS. IF BURNER HAS FAILED TO LIGHT, OR IF BURNER LIGHTS THEN GOES OUT AND SYSTEM GOES INTO SAFETY LOCKOUT, DE-ENERGIZE THE SYSTEM BY SETTING OPERATING CONTROL TO **OFF** OR THERMOSTAT BELOW ROOM TEMPERATURE FOR AT LEAST 30 SECONDS TO RESET THE SYSTEM.
6. REPEAT STEP 4 FOR RESTART.

TO SHUT OFF

1. TURN MANUAL GAS COCK **OFF**.
2. TURN BURNER POWER **OFF**.

SHOULD OVERHEATING OF THE APPLIANCE OCCUR

1. Shut off the manual gas control to the appliance.
2. **Do not** shut off the electrical supply power to the blower.

TROUBLE CHART

Make sure the thermostat and operating controls are calling for heat. Defective wiring or loose connections can simulate the component defects outlined below. Check associated wiring before replacing a component.

ELECTRICAL AND FLAME CHECKS MUST BE MADE IN ORDER LISTED.

- I Confirm 120V between strip terminals **1** and **2** and verify the circuit polarity and electrical ground, between strip terminal **1** and burner chassis metal.
- II
 - A. Confirm that both Main Manual Shut-Off Valve and Manual Gas Cock Knob on Combination Gas Valve are in the **ON** position.
 - B. Whenever the burner fails to light during the 6-second trial for ignition, or if the flame is lost during the burner run and not re-established within 36 seconds the Electronic Control will shut off the Combination Valve and **LOCK OUT**. To **RESET** the Control for restart, set the operating control to **OFF** or thermostat below room temperature for at least 30 seconds.
 1. Check for 24V* between strip terminal **GND** and Electronic Control **25V** terminal. No voltage, blower interlock circuit is defective.
 2. If Electronic Control has a fuse, test for 24V from each end of fuse to strip terminal **GND**.
 - C. For each of the following tests, reset the Electronic Control per step II.B. **TESTS ARE VALID ONLY DURING THE 6 SECOND TRIAL FOR IGNITION.**
 1. **Turn Manual Gas Cock Knob to Off.** Check for 24V between the Electronic Control

Part 3
Maintenance Continued
Trouble Chart
Continued

III **Flame on**
Only During
6-Second Trial
for Ignition

- VALVE** terminal and the other Electronic Control **VALVE** . No voltage, defective Electronic control.
2. Check for 24V* between valve **MV** terminal and valve body: With voltage, **RESET** Electronic Control and listen for audible **CLICK** as valve operators open. No **CLICK**, replace valve.
 3. Check for ignition spark (spark length approximately $\frac{1}{8}$ "). Since this is a capacitor discharge system, observe closely when visually checking the spark as it is faint and thread-like and may be overlooked in bright light.
 - a. Between Electronic Control high voltage terminal and strip terminal **GND**. No spark, defective Electronic Control.
 - b. Between Electronic Control high voltage terminal and Spark Electrode Wire (insert head of #8 x $\frac{3}{4}$ " or longer round head screw into snap terminal inside right angle rubber boot). No spark, broken wire, cracked insulator, or "spark gap" too wide, see Figures 7A and 7B.
 - c. Between spark electrode tip and top of ground rod, see Figures 7A and 7B. If spark is not visible and/or can not be heard, remove nozzle assembly (see Section IX **Electrodes**) and ground it solidly to burner metal. No spark, cracked insulator and spark traveling to ground along crack.
 4. **Turn Manual Gas Cock Knob to ON**. Connect manometer to the manifold gas pressure tap and during trial for ignition, check the gas pressure:
 - a. Pressure should be between 2.0" and 4.0" W.C. for NATURAL and PROPANE and steady. Verify per Section VII (*Main Gas Input Selection*) and Table 3 (*Capacity and Preliminary Gas Settings*) that the orifice size and manifold pressure are correct.
 - b. Zero, erratic low or high pressure: confirm that the inlet pressure to the Combination Valve is between 5" and 14" W.C. for NATURAL and PROPANE during standby and during trial for ignition.
 - c. If manifold pressure is zero, below 2.0" or above 4.0" W.C. for NATURAL and PROPANE or erratic, the regulator section of the Combination Valve is defective and the entire valve must be replaced.

- III A. With motor running check burner line voltage terminals for 120V as follows:
 1. Between strip terminals **L1** and **L2**-120V; voltage OK.
 2. Between strip terminals **L1** and **GND**-120V: ground OK.
 3. Between strip terminals **L2** and **L2**-"0"V: no back-feed, OK
- B. Follow **RESET** procedure as specified in step II.B.
 1. Check sense electrode position per Figure 7A or 7B
 2. Check sense wire for continuity.
 3. Connect DC microammeter in series with Electronic Control **SENSE** terminal and sensor wire. With flame on, flame signal should be at least 2 microamps.
- C. **IMPORTANT:** If Changes are made in the Main Orifice size, Manifold Gas Pressure or Primary Air Adjustment, change the installation data tag accordingly.

IV **Short**
Flame**

- IV A. Low manifold gas pressure.
- B. Main gas orifice too small.

V **Long Hazy**
Flame**

- V A. High manifold gas pressure.
- B. Main gas orifice too large.
- C. Primary air adjustment closed too far.
- D. Dirty blower wheel.

VI **Gas Fails to**
Shut Off

- VI A. Wutomatic electric (redundant) valve section of Combination Valve is defective and entire valve must be replaced.

* Normal low voltage:
Motor running-24V minimum.
Combination Valve energized-21V minimum.

**  **CAUTION: If changes are made in the Main Gas Orifice size, Manifold Gas Pressure or Primary Air Adjustment, change the installation data tag accordingly.**

